



# X-Peak 3 Plus Charger

## INSTRUCTIONS

### Dear Customer

Thank you for purchasing this charger, we are sure you will be pleased with its performance. In order to ensure you obtain the maximum from its operation, please read the following instructions carefully

### Special Features

- \* Input voltage is 11~15V DC
- \* Capable of charging and discharging 1 - 14 NiCd or NiMH cells, 1 - 5 Lithium-Ion or Lithium-Polymer cells, or 2 ~ 12V lead-acid batteries
- \* Adjustable charge current ( 0.1A - 5.0A)
- \* Adjustable discharge current ( 0.1A - 1.0A)
- \* " zero delta V " peak detection for NiCd and NiMH batteries
- \* " constant current / constant voltage " charge method for Lithium-Ion/Po batteries and Pb batteries.
- \* Conpack & portable side
- \* Cycling( Charge to Discharge / Discharge to Charge )
- \* 2 -line, 16 character LCD can make the screen extremely clear and legible.
- \* Various warning messages for improper input voltage, wrong connections, unsuitable battery condition, reverse polarity on output
- \* Packaged in a rugged, extruded aluminum case

### Specification

|                        |  |
|------------------------|--|
| Input voltage          | 11.0-15.0V DC  |
| Battery type & cells   | 1-14 Nickel-Cadmium cells  |
|                        | 1-14 Nickel-Metal Hydride cells                                  |
|                        | 1-5 Lithium-Ion or Lithium-Polymer cells ( type : 3.6V or 3.7V ) |
|                        | 1 - 6 Lead-Acid cells ( 2V per cell )                            |
| Charge current         | 0.1A ~ 5A  |
| Discharge current      | 0.1A ~ 1A  |
| Trickle charge current | 0 ~ 250mA  |
| Charge termination     | " zero delta V" peak detection for NiCd/NiMH                     |
|                        | " constant current / constant voltage " for Li-Ion/Po and Pb     |
| Cycling                | Charge to Discharge / Discharge to Charge                        |
| Display type           | 2-line, 16 backlit character LCD                                 |



### **Safety precautions**

- \* Do NOT attempt to charge incompatible types of rechargeable batteries. This charger is designed to only charge and discharge nickel-cadmium, nickel-metal hydride, lithium-ion, and lithium-polymer batteries.
  
- \* Make sure to place the charger on a firm level surface for charging.
- \* Do not attempt to charge batteries at excessive fast charge currents.
- \* Do not use automotive type battery chargers to power the charger.
- \* Do not leave the charger unattended while charging. **Disconnect the battery and remove input power from charger immediately if the charger becomes hot.** Allow the charger or battery to cool down before reconnecting.
- \* Do not allow water, moisture or foreign objects into the charger.
- \* Do not place the battery or charger on or near a flammable object while in use. Keep away from carpets, cluttered workbenches, etc.
- \* Do not cover the air intake holes on the charger as this could cause the charger to overheat.
- \* Connect the input leads to a 12V power supply first, then connect the battery.
- \* Do not disassemble the charger.

### **Input power**

Connect the charger to the 12V DC power supply.

Connect the charger's red alligator clip to the positive (+) terminal on the power source, and the black alligator clip to the negative (-) terminal. The charger will display "Input voltage" error message if the input is below 11V, or above 15V. If this happens, please recheck the input power supply to make sure adequate power is present.

### **Output battery connections**

Two banana sockets are located on the right side of the charger. Connect the battery charge lead to these sockets with the positive (+) lead connected to the red socket and the negative (-) lead to the black socket. "No battery" error message will be displayed if trying to start charge without connecting a battery. "Open circuit" error message will be displayed if a battery become disconnected from the charger while a function in progress. "Reverse polarity" error message will be displayed if a battery is connected to the charger in reverse.

### **Operation**

When the charger is connected to the power supply, the following display will be shown.

A yellow rectangular box with a blue border, representing the display on the charger. It contains the text "X-Peak 3" on the top line and "Version 2.0" on the bottom line.

X-Peak 3  
Version 2.0



After showing the above initial display, the charger will show a battery mode that has been lastly used.

If the Battery type button is briefly pressed, the present battery type ( NiCd, NiMH, Lithium, or Pb ) is blinking.

While the existing battery type is blinking, every time the Battery type button is pressed, the following modes are shown in order. NiCd→ NiMH→ Lilo→ Pb→ NiCd

. If the other buttons are pressed, or nothing is pressed, the present battery type stops blinking.

. If the Battery type button is pressed long, the recent & previous data will be shown for 3 seconds.

. If the Enter button is briefly pressed, a parameter which can be adjusted, starts to blink, and if the Enter button is pressed again, next parameter starts to blink. If nothing is pressed for 3 seconds, a parameter stops blinking.

. Once the Enter button is pressed long, the charger starts to charge or discharge.

**NiCd MODE**

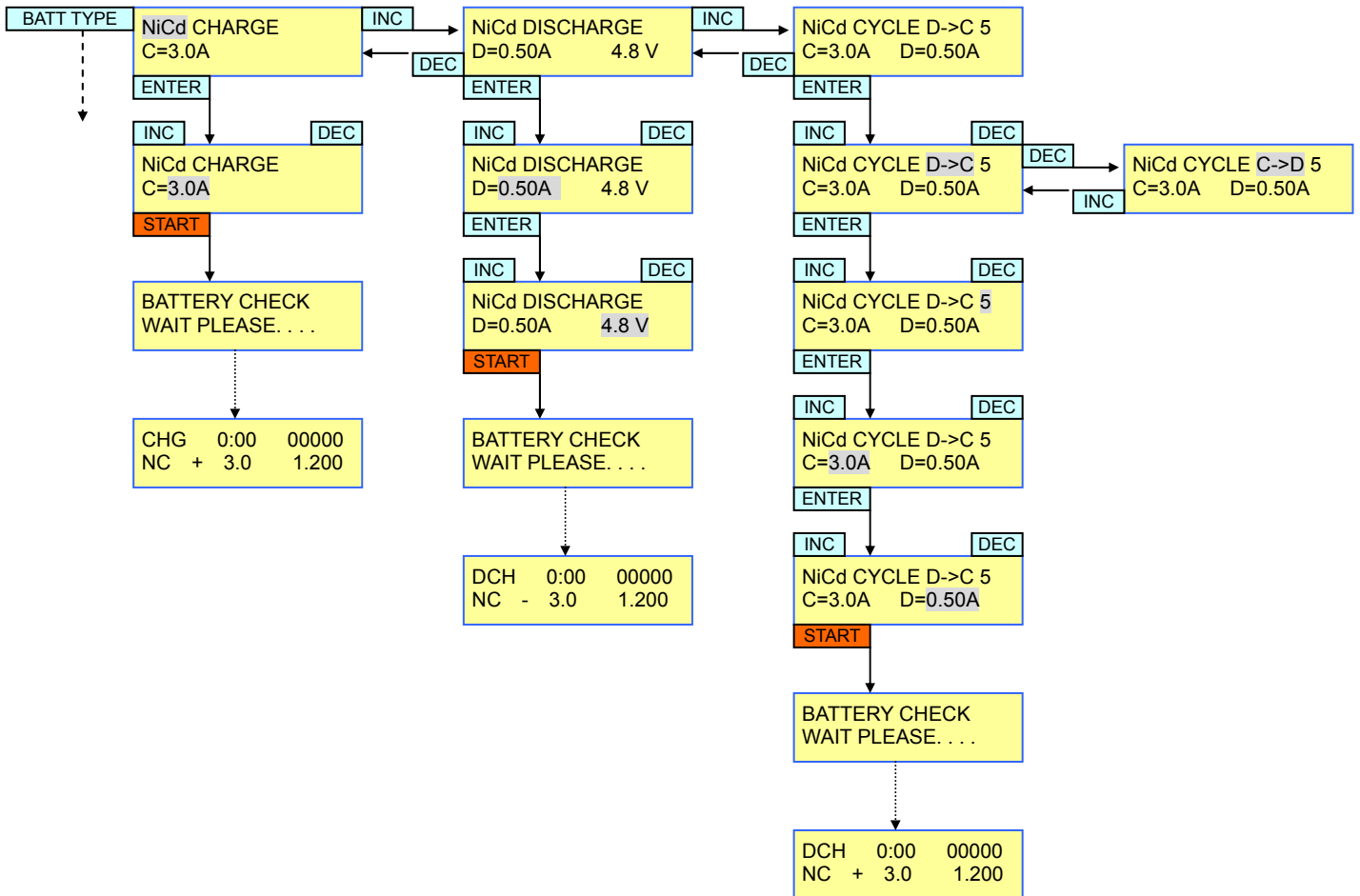

NiCd CHARGE  
C=3.0A

**Setting charge current**

Adjust and find the desired charge current which ranges from 0.1A to 5.0A with INC & DEC buttons. Press the ENTER button to confirm setting.





NiMH CHARGE  
C=3.0A

**Setting charge current**

Adjust and find the desired charge current which ranges from 0.1A to 5.0A with INC & DEC buttons. Press the ENTER button to confirm setting.

NiMH DISCHARGE  
D=0.50A 4.8 V

**Setting discharge current**

Adjust and find the desired discharge current which ranges from 0.1A to 1A with INC & DEC buttons. Press the ENTER button to confirm setting.

NiMH DISCHARGE  
D=0.50A 4.8 V

**Setting discharge cutoff voltage**

This is the voltage that the charger should stop discharging the battery.  
Adjust and find total discharge cutoff voltages to be discharged from 0.1V to 16.8V with INC & DEC buttons. Press the ENTER button to confirm setting.

NiMH CYCLE C->D 5  
C=3.0A D=0.50A

**Setting cycle**

This is to set cycling with two options ( Charge to Discharge / Discharge to Charge). Set cycling with INC & DEC buttons, and press the ENTER button to confirm setting.

**Li-Ion & Li-Po MODE**

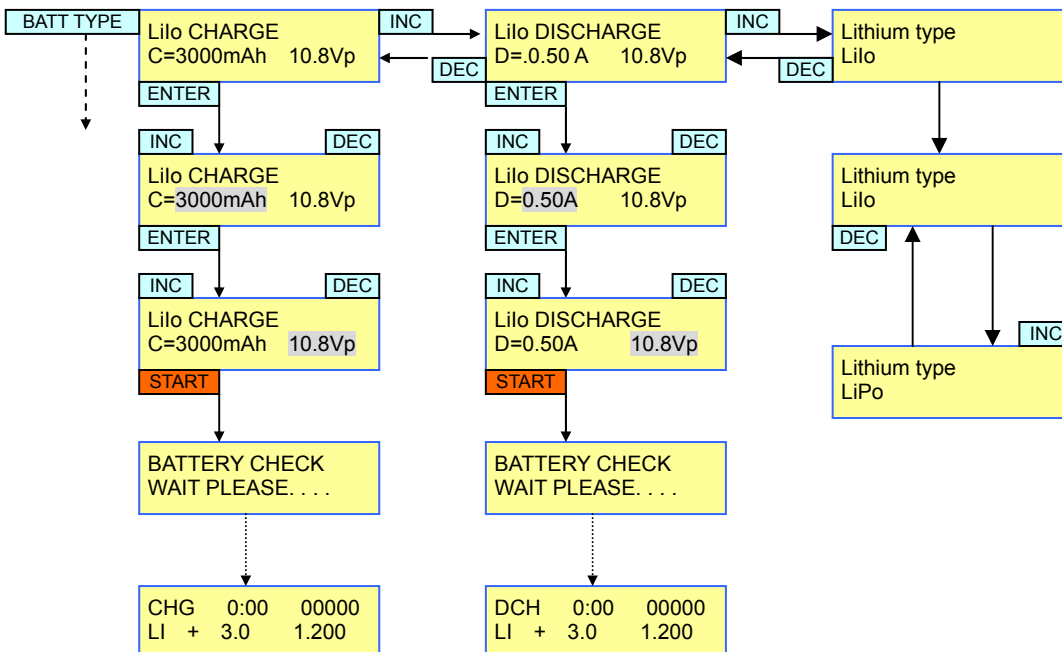



This charger is capable of charging Lithium-ion and Lithium-polymer batteries up to 5 lithium cells. This charger is using the “ constant current / constant voltage “ in order to fully charge Lithium-ion & Lithium-polymer batteries. Constant current is delivered during the fast charge. When the voltage of the Li-Ion or Li-Po battery is reached approx 4.0V per cell, the charger starts to change its charge method from “constant current” to “ constant voltage “. The “ constant voltage “ allows the battery to dictate how much current the charger should deliver for safe, full charges. When the current drops below approx 100mA, the charger should stop charging as the battery is fully charged.

Lilo CHARGE  
C=3000mAh 10.8Vp

**Setting battery capacity**

Adjust and set the desired battery capacity from 100mAh to 5000mAh

(50mAh per step) with INC & DEC buttons. Press the ENTER button to confirm setting.

Lilo CHARGE  
C=3000mAh 10.8Vp

**Setting battery voltages for Li-Ion battery pack**

Select the proper total battery voltages to be charged or discharged with INC & DEC buttons – 3.6V, 7.2V, 10.8V, 14.4V, and 18.0V [Vpack]

LiPo CHARGE  
C=3000mAh 11.1Vp

**Setting battery voltages for Li-Po battery pack**

Select the proper total battery voltages to be charged or discharged with INC & DEC buttons – 3.7V, 7.4V, 11.1V, 14.8V, and 18.5V [Vpack]

Lilo DISCHARGE  
D=0.50 A 10.8Vp

**Setting discharge current**

Adjust and find the desired discharge current from 0.10A to 1.00A (0.01A per step) with INC & DEC button. Press the ENTER button to confirm setting.

Lithium type  
LiPo

**Setting battery type**

Choose the desired battery type ( either Li-Ion or Li-Po ) with INC & DEC buttons. Press the ENTER button to confirm setting.

For the safety purpose, this charger is designed to automatically deliver 1C charge rate to the batteries of either Li-Ion or Li-Po based on user selected battery capacity.

Example : Li-Po cell of 1500mAh capacity : 1C = 1500mAh ( = 1.5A ) charge current.

**Note : The maximum voltage for Li-Ion batteries is 4.1V per cell, and 4.2V per cell for Li-Po batteries. Therefore, it is extremely important to choose the proper battery type to be charged as Li-Ion and Li-Po batteries have the different voltage level. Unless otherwise, it may cause very serious damage to the batteries and the surrounding area !**



**Pb MODE**

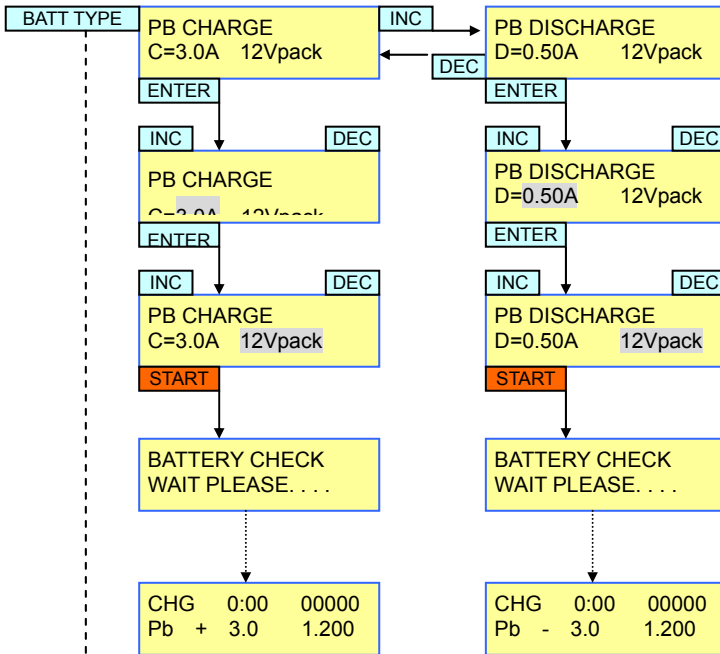

to NiCd charge

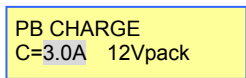

**Setting charge current**

Adjust and find the desired charge current which ranges from 0.1A to 5.0A with INC & DEC buttons. Press the ENTER button to confirm setting

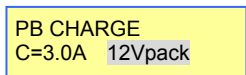

**Setting battery voltages for Li-Ion battery pack**

Select the proper total battery voltages to be charged or discharged with INC & DEC buttons – 2V, 4V, 6V, 8V, 10V, and 12V [Vpack]

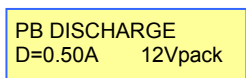

**Setting discharge current**

Adjust and find the desired discharge current from 0.10A to 1.00A (0.01A per step) with INC & DEC button. Press the ENTER button to confirm setting.

**Displays during charge, discharge, and cycle**

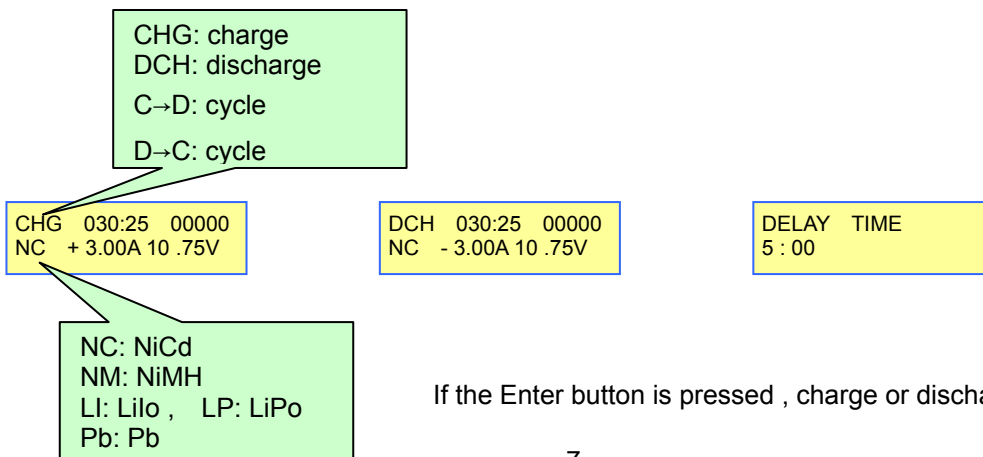

**Completion display**

```
END 030:00 00000
NC 100mA 10.75V
```

In order to move to the main display, press the Enter button.

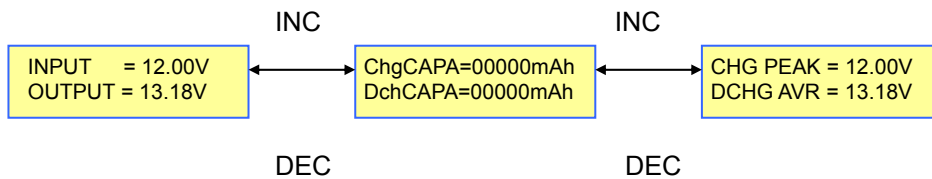
**Data display**

If the Battery type button is pressed for over 3 seconds, Data view will be displayed as above.

Data displays can be scrolled left and right by INC & DEC buttons.

If nothing is pressed for 3 seconds, this display is disappeared.

**Error messages**

|                                    |  |
|------------------------------------|--|
| INPUT BATTERY<br>VOLTAGE ERROR     | . When input voltage is below 11.0V or exceeds 15V.  |
| NO BATTERY                         | . When a battery is not connected to the charger's output  |
| OUTPUT BATTERY<br>REVERSE POLARITY | . When a battery is connected to the output in reverse   |
| OUTPUT CIRCUIT<br>PROBLEM          | When the circuit of the charger has a problem  |
| CHECK THE BATT.<br>OPEN CIRCUIT    | . When a battery becomes disconnected during an operation  |
| CHECK THE BATT.<br>OVER VOLTAGE    | If wrong voltages are set while charging lithium or Pb batteries.                                  |
| CHECK THE BATT.<br>LOW VOLTAGE     | If wrong voltages are set or batteries are over discharged while charging Lithium or Pb batteries. |



### CHARGE MAXIUM CURRENT(50W)

NiCd / NiMH battery charge limit

Based on 1.5V per cell

| Cells  | Voltage | Limited Current |
|--------|---------|-----------------|
| 1cell  | 1.5V    | 5.00A           |
| 2cell  | 3.0V    | 5.00A           |
| 3cell  | 4.5V    | 5.00A           |
| 4cell  | 6.0V    | 5.00A           |
| 5cell  | 7.5V    | 5.00A           |
| 6cell  | 9.0V    | 5.00A           |
| 7cell  | 10.5V   | 4.75A           |
| 8cell  | 12.0V   | 4.00A           |
| 9cell  | 13.5V   | 3.70A           |
| 10cell | 15.0V   | 3.30A           |
| 11cell | 16.5V   | 3.00A           |
| 12cell | 18.0V   | 2.75A           |
| 13cell | 19.5V   | 2.50A           |
| 14cell | 21.0    | 2.30A           |

Lithium-ion battery charge limit

| Pack Volt | Cells | Max Volt | Limited Current |
|-----------|-------|----------|-----------------|
| 3.6V      | 1cell | 4.1V     | 5.00A           |
| 7.2V      | 2cell | 8.2V     | 5.00A           |
| 10.8V     | 3cell | 12.3V    | 4.00A           |
| 14.4V     | 4cell | 16.4V    | 3.00A           |
| 18.0V     | 5cell | 20.5V    | 2.50A           |

Lithium-polymer battery charge limit

| Pack Volt | Cells | Max Volt | Limited Current |
|-----------|-------|----------|-----------------|
| 3.7V      | 1cell | 4.2V     | 5.00A           |
| 7.4V      | 2cell | 8.4V     | 5.00A           |
| 11.1V     | 3cell | 12.6V    | 4.00A           |
| 14.8V     | 4cell | 16.8V    | 3.00A           |
| 18.5V     | 5cell | 21.0V    | 2.30A           |



### DISCHARGE MAXIUM CURRENT(5W)

NiCd / NiMH battery charge limit

Based on 1.2V per cell

| Cells  | Voltage | Limited Current |
|--------|---------|-----------------|
| 1cell  | 1.20V   | 1.00A           |
| 2cell  | 2.40V   | 1.00A           |
| 3cell  | 3.60V   | 1.00A           |
| 4cell  | 4.80V   | 1.00A           |
| 5cell  | 6.00V   | 0.83A           |
| 6cell  | 7.20V   | 0.69A           |
| 7cell  | 8.40V   | 0.60A           |
| 8cell  | 9.60V   | 0.52A           |
| 9cell  | 10.8V   | 0.46A           |
| 10cell | 12.0V   | 0.42A           |
| 11cell | 13.2V   | 0.38A           |
| 12cell | 14.4V   | 0.35A           |
| 13cell | 15.6V   | 0.32A           |
| 14cell | 16.8V   | 0.30A           |

Lithium-ion battery charge limit

based on 3.6V per cell

| Pack Volt | Cells | Limited Current |
|-----------|-------|-----------------|
| 3.6V      | 1cell | 1.00A           |
| 7.2V      | 2cell | 0.69A           |
| 10.8V     | 3cell | 0.46A           |
| 14.4V     | 4cell | 0.35A           |
| 18.0V     | 5cell | 0.28A           |

Lithium-polymer battery charge limit

based on 3.7V per cell

| Pack Volt | Cells | Limited Current |
|-----------|-------|-----------------|
| 3.7V      | 1cell | 1.35A           |
| 7.4V      | 2cell | 0.68A           |
| 11.1V     | 3cell | 0.45A           |
| 14.8V     | 4cell | 0.34A           |
| 18.5V     | 5cell | 0.27A           |